



US007310903B2

(12) **United States Patent**  
**Kim**

(10) **Patent No.:** **US 7,310,903 B2**  
(45) **Date of Patent:** **Dec. 25, 2007**

(54) **ACCESSORY DEVICES FOR FIREARMS**

(75) Inventor: **Paul Y. Kim**, Santa Ana, CA (US)

(73) Assignee: **Surefire, LLC**, Fountain Valley, CA (US)

982,280 A 1/1911 Lewis  
1,120,769 A 12/1914 Villarejo  
1,149,705 A 8/1915 Ward  
1,215,171 A 2/1917 Lewis  
1,222,778 A 4/1917 McCleary  
1,262,270 A 4/1918 Schmidt et al.  
1,263,667 A 4/1918 Henderson et al.

(\*) Notice: Subject to any disclaimer, the term of this patent is extended or adjusted under 35 U.S.C. 154(b) by 0 days.

(Continued)

**FOREIGN PATENT DOCUMENTS**

(21) Appl. No.: **11/443,612**

AT 274620 12/1968

(22) Filed: **May 30, 2006**

(Continued)

(65) **Prior Publication Data**

US 2007/0068059 A1 Mar. 29, 2007

**OTHER PUBLICATIONS**

Insight Technology, "M3X Operator's Manual", dated Jul. 2003.

(Continued)

**Related U.S. Application Data**

(62) Division of application No. 10/819,535, filed on Apr. 6, 2004, now Pat. No. 7,117,624.

*Primary Examiner*—J. Woodrow Eldred  
(74) *Attorney, Agent, or Firm*—David Weiss

(51) **Int. Cl.**  
**F41A 15/00** (2006.01)

(52) **U.S. Cl.** ..... **42/90**; 42/114; 42/113;  
42/117; 42/131; 200/60; 200/523; 200/526;  
200/527; 200/570

(58) **Field of Classification Search** ..... 200/60,  
200/523, 526, 527, 570, 572; 42/90, 114,  
42/113, 117, 131

See application file for complete search history.

(57) **ABSTRACT**

An accessory device for a firearm, a preferred embodiment comprising a housing, a light emitter assembly and a battery carried by the housing in circuit for energizing the light emitter assembly when switch actuated, and a tail cap switch device secured to the housing and including a switch actuator having an actuator arm rotatably urgeable by either hand of an operator clockwise or counterclockwise about the housing's longitudinal direction for placing the switch in a CONSTANT ON position from an OFF position, the actuator arm reverse rotatably urgeable by the operator for returning the switch to the OFF position, and the actuator arm having opposed ends longitudinally urgeable by the operator from the OFF position for placing the switch in a MOMENTARY ON position.

(56) **References Cited**

**U.S. PATENT DOCUMENTS**

689,547 A 12/1901 James  
894,306 A 7/1908 Wright  
933,095 A 9/1909 Mosteller  
957,299 A 5/1910 Barnes  
958,332 A 5/1910 Snyder

**11 Claims, 5 Drawing Sheets**

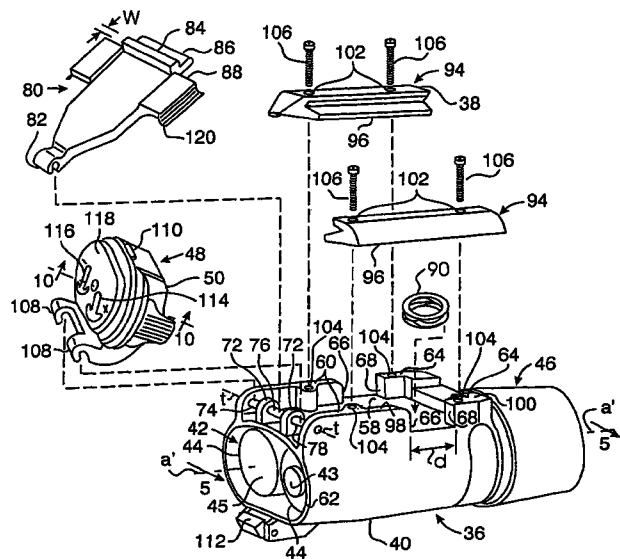

# US 7,310,903 B2

Page 2

U.S. PATENT DOCUMENTS					
			4,446,644	A	5/1984 Jimenez et al.
1,338,239	A	4/1920 Matys	4,542,447	A	9/1985 Quakenbush
1,427,042	A	8/1922 Wetmore	4,554,744	A	11/1985 Huckenbeck
1,452,651	A	4/1923 Norrlin	4,561,775	A	12/1985 Patrick et al.
1,826,004	A	10/1931 Key	4,571,870	A	2/1986 Heideman et al.
1,865,127	A	6/1932 McKeen	4,580,362	A	4/1986 Stevens
1,877,016	A	9/1932 Munson	4,627,183	A	12/1986 Stuckman
1,993,979	A	3/1935 Reed	4,658,139	A	4/1987 Brennan et al.
2,017,585	A	10/1935 Casey	4,665,622	A	5/1987 Idan
2,085,732	A	7/1937 Baxter et al.	4,697,226	A	9/1987 Verdin
2,108,475	A	2/1938 Cooper	4,707,595	A	11/1987 Meyers
2,158,915	A	5/1939 Searcy	4,738,044	A	4/1988 Osterhout
2,209,524	A	7/1940 Key	4,777,754	A	10/1988 Reynolds, Jr.
2,236,736	A	4/1941 Scott	4,779,370	A	10/1988 Cormack
2,314,061	A	3/1943 Whaley	4,799,325	A	1/1989 Booze
2,336,718	A	12/1943 Davis	4,825,744	A	5/1989 Glock
2,385,649	A	9/1945 Prideaux	4,853,529	A	8/1989 Meyers
2,450,584	A	10/1948 Dodge	4,856,218	A	8/1989 Reynolds, Jr.
2,529,057	A	11/1950 Teffault	4,876,815	A	10/1989 Terrill
2,546,242	A	3/1951 Stinson	4,876,816	A	10/1989 Triplett
2,597,565	A	5/1952 Chandler et al.	4,893,546	A	1/1990 Glock
2,645,017	A	7/1953 Haase	4,894,941	A	1/1990 Karow, Jr.
2,657,303	A	10/1953 Dickens	4,905,396	A	3/1990 Bechtel
2,844,710	A	9/1958 Zinsser	4,916,579	A	4/1990 Simms
2,912,566	A	11/1959 Cornett	4,916,713	A	4/1990 Gerber
3,010,019	A	11/1961 Sohst	4,926,576	A	5/1990 Maes et al.
3,019,542	A	2/1962 Manthos	4,934,085	A	6/1990 Lough
3,153,856	A	10/1964 Felix	4,939,863	A	7/1990 Alexander et al.
3,222,022	A	12/1965 Akin, Jr.	4,991,183	A	2/1991 Meyers
3,222,511	A	12/1965 Breeding	4,993,833	A	2/1991 Lorey et al.
3,243,896	A	4/1966 Immarco et al.	RE33,572	E	4/1991 Meyers
3,417,237	A	12/1968 Fenton	5,026,158	A	6/1991 Golubic
3,447,033	A	5/1969 Redmond et al.	5,031,349	A	7/1991 Vogel
3,454,898	A	7/1969 Comstock	5,036,517	A	7/1991 Meyers
3,509,344	A	4/1970 Bouwers	5,040,322	A	8/1991 Iturrey, Jr.
3,513,581	A	5/1970 Slater	5,040,885	A	8/1991 Simms
3,562,944	A	2/1971 Wagner et al.	5,042,048	A	8/1991 Meyer
3,633,285	A	1/1972 Sensney	5,052,801	A	10/1991 Downes, Jr. et al.
3,656,845	A	4/1972 Koch-Bossard et al.	5,056,097	A	10/1991 Meyers
3,739,167	A	6/1973 Avery	5,058,900	A	10/1991 Denen
3,742,636	A	7/1973 Dealy et al.	5,064,988	A	11/1991 E'nama et al.
3,782,832	A	1/1974 HacsKaylo	5,090,805	A	2/1992 Stawarz
3,787,693	A	1/1974 Stone	5,107,612	A	4/1992 Bechtel
3,834,052	A	9/1974 Steck, III	5,111,587	A	5/1992 Plank
3,867,764	A	2/1975 Dunmire et al.	5,118,186	A	6/1992 Schratzenstaller et al.
3,877,166	A	4/1975 Ward	5,205,044	A	4/1993 DePaoli
3,898,747	A	8/1975 Marshall	5,221,956	A	6/1993 Patterson et al.
3,938,262	A	2/1976 Dye et al.	5,249,501	A	10/1993 Waldman et al.
3,974,585	A	8/1976 Dunham	5,272,514	A	12/1993 Dor
3,995,376	A	12/1976 Kimble et al.	5,299,375	A	4/1994 Thummel et al.
4,000,403	A	12/1976 Rice	5,309,337	A	5/1994 Groben
4,026,054	A	5/1977 Snyder	5,355,608	A	10/1994 Teetzel
4,027,159	A	5/1977 Bishop	5,358,135	A *	10/1994 Robbins et al. .... 220/834
4,044,486	A	8/1977 Van Holten	5,374,986	A	12/1994 Solinsky
4,069,414	A	1/1978 Bell	5,400,540	A	3/1995 Solinsky et al.
4,079,534	A	3/1978 Snyder	5,425,299	A	6/1995 Teetzel
4,112,300	A	9/1978 Hall, Jr. et al.	5,426,880	A	6/1995 Ruger et al.
4,152,754	A	5/1979 deFilippis et al.	5,430,967	A	7/1995 Woodman, III et al.
4,161,076	A	7/1979 Snyder	5,471,777	A	12/1995 McDonald
4,168,588	A	9/1979 Snyder	5,481,819	A	1/1996 Teetzel
4,212,109	A	7/1980 Snyder	5,526,749	A	6/1996 Teetzel
4,266,873	A	5/1981 HacsKaylo et al.	5,555,662	A	9/1996 Teetzel
4,281,993	A	8/1981 Shaw	5,581,898	A	12/1996 Thummel
4,291,479	A	9/1981 Lough	5,584,137	A	12/1996 Teetzel
4,295,289	A	10/1981 Snyder	5,642,932	A	7/1997 Matthews
4,310,980	A	1/1982 Pilkington	5,654,594	A	8/1997 Bjornsen, III et al.
4,313,272	A	2/1982 Matthews	5,669,174	A	9/1997 Teetzel
4,313,273	A	2/1982 Matthews et al.	5,685,105	A	11/1997 Teetzel
4,315,150	A	2/1982 Darringer et al.	5,758,448	A	6/1998 Thummel
4,383,371	A	5/1983 Coffey	5,816,683	A	10/1998 Christiansen
4,417,814	A	11/1983 Doliber	5,849,007	A	12/1998 Fuhrberg et al.
4,418,487	A	12/1983 Strahan	6,112,962	A	9/2000 Matthews
			6,185,854	B1	2/2001 Solinsky et al.

# US 7,310,903 B2

Page 3

---

6,190,025	B1	2/2001	Solinsky		DE	1101223	9/1959
6,222,138	B1 *	4/2001	Matthews et al. ....	200/4	EP	0 335 281 A2	10/1989
6,276,088	B1	8/2001	Matthews et al.		FR	2 592 149 A1	6/1987
6,363,648	B1	4/2002	Kranich et al.		GB	13444	11/1885
6,378,237	B1	4/2002	Matthews et al.		GB	818524	8/1959
6,508,027	B1	1/2003	Kim		GB	2 052 025 A	1/1981
6,574,901	B1	6/2003	Solinsky et al.				
6,606,813	B1	8/2003	Squire et al.				
6,622,416	B2	9/2003	Kim				
6,629,381	B1	10/2003	Keng				
6,646,211	B2 *	11/2003	Taniuchi et al. ....	200/4			
6,655,069	B2	12/2003	Kim				
6,851,214	B2	2/2005	Oz				
2001/0022044	A1	9/2001	Spinner				
2003/0101632	A1	6/2003	Davenport et al.				

## FOREIGN PATENT DOCUMENTS

CH 217521 10/1941

## OTHER PUBLICATIONS

United States Department of Defense, Military Standard: Dimensioning of Accessory Mounting Rail for Small Arms Weapons, MIL-STD-1913, Feb. 3, 1995.  
GLOCK INC., Glock Perfection Instructions for Use, Aug. 1999.  
Insight Technology Incorporated, M3 Tactical Illuminator Operator Manual, date prior to Apr. 2003.  
SUREFIRE, LLC, 2002 Surefire Weaponlight Catalog (including pp. 8-12 and 52), date 2002.

\* cited by examiner

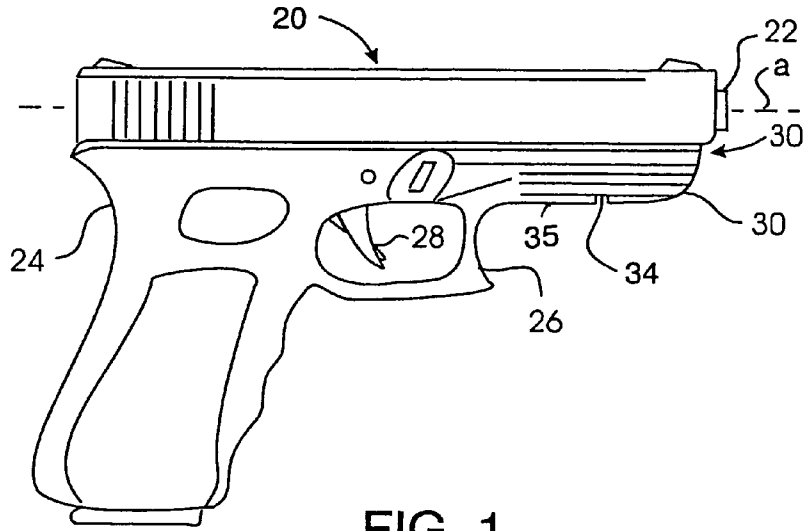

FIG. 1

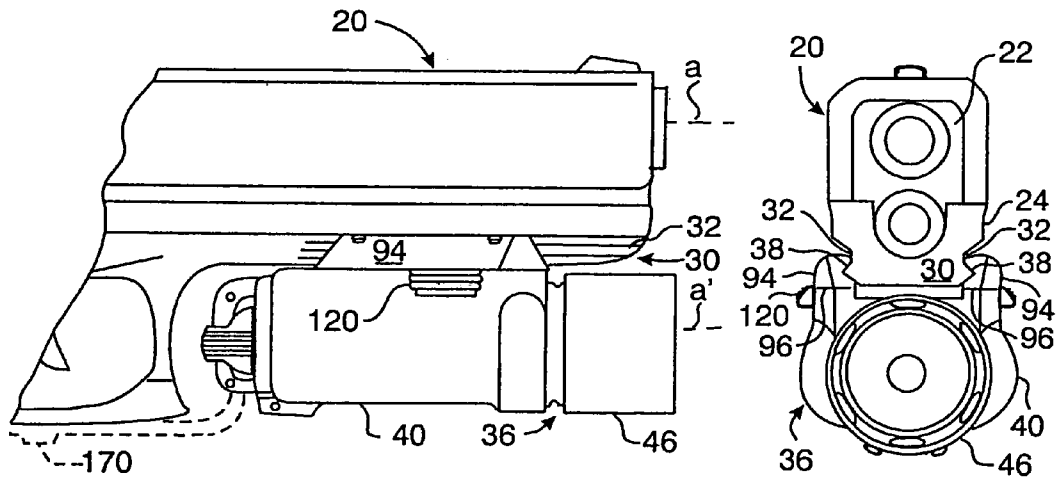

FIG. 2

FIG. 3

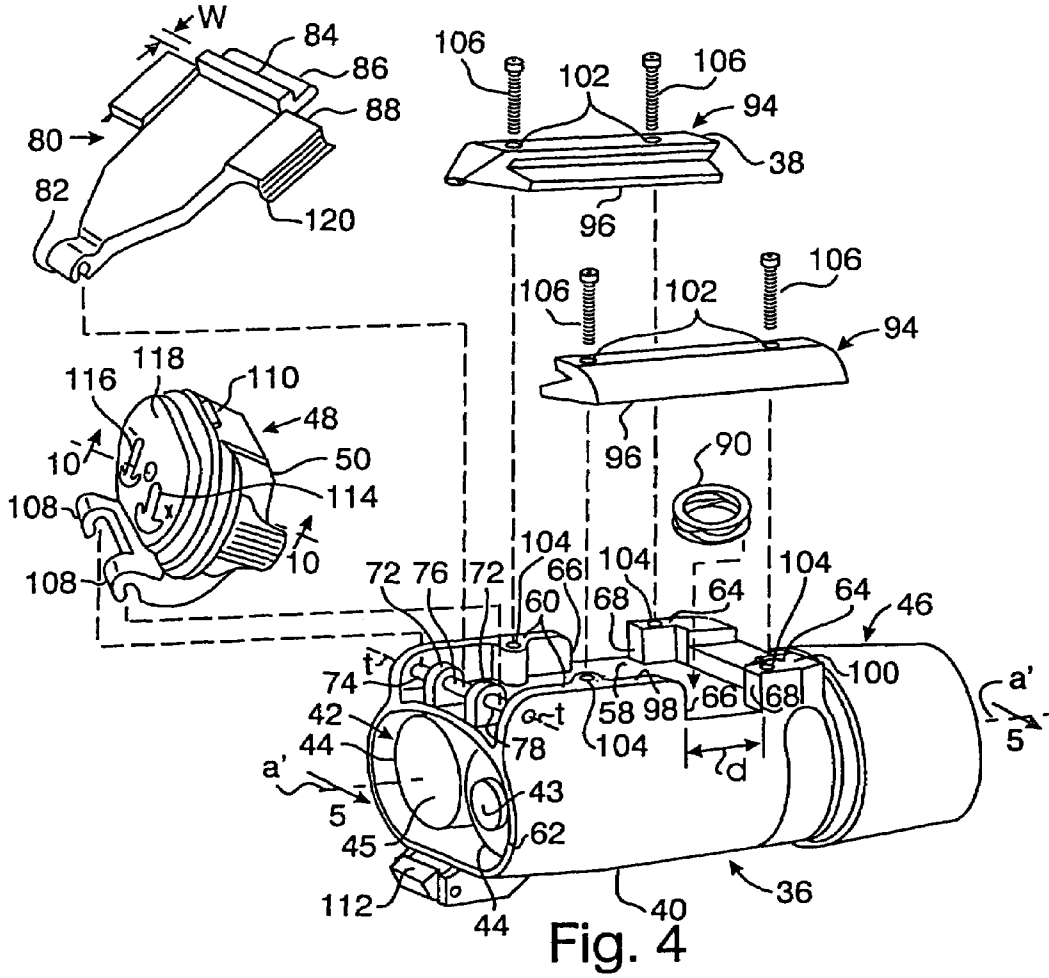

Fig. 4

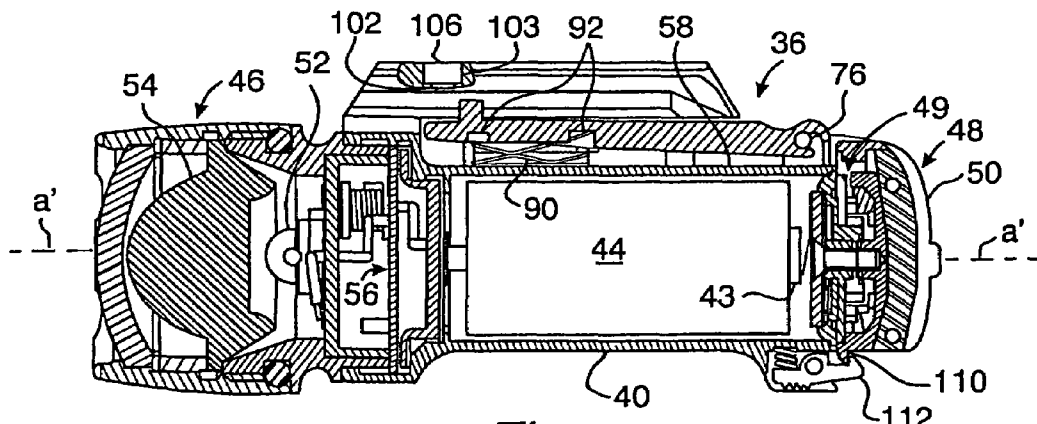

Fig. 5

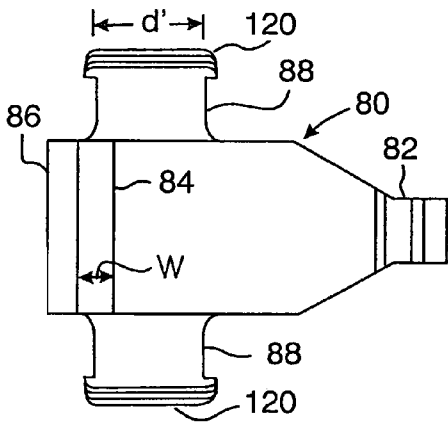

FIG. 6

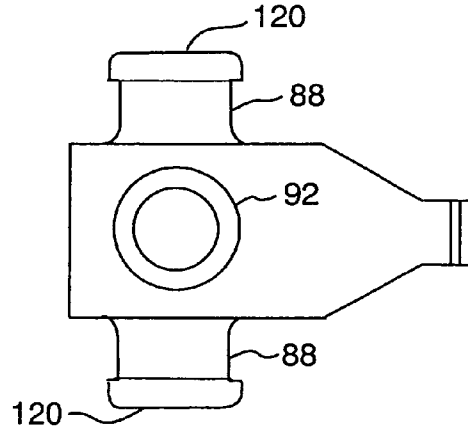

FIG. 7

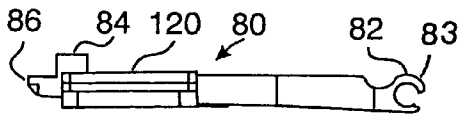

FIG. 8

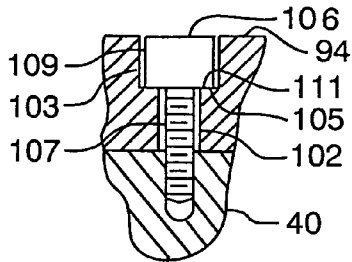

Fig. 9

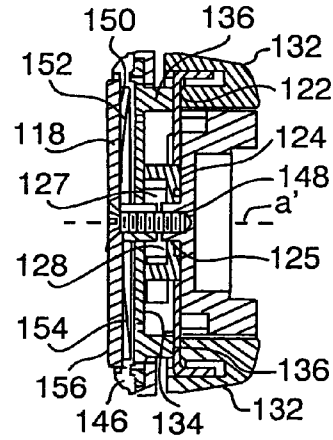

FIG. 10

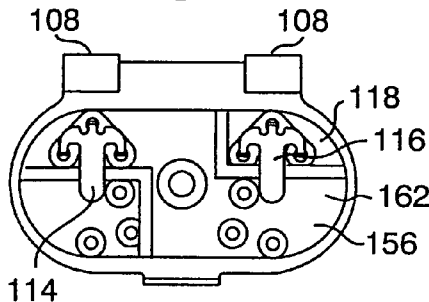

FIG. 11

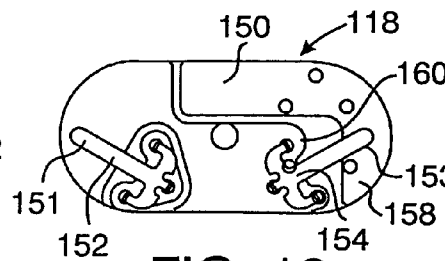

FIG. 12

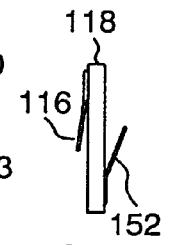

FIG. 13

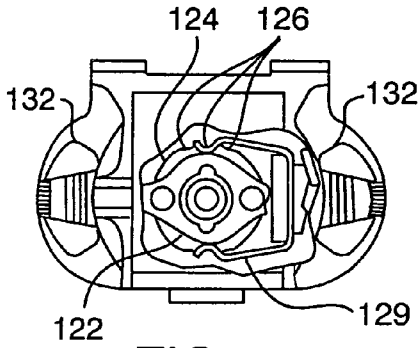

FIG. 14

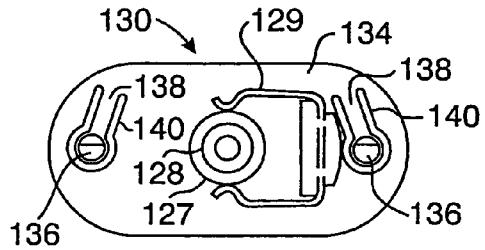

FIG. 15

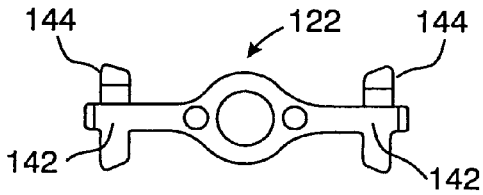

FIG. 16

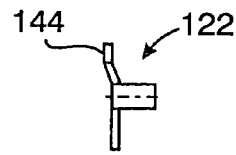

FIG. 17

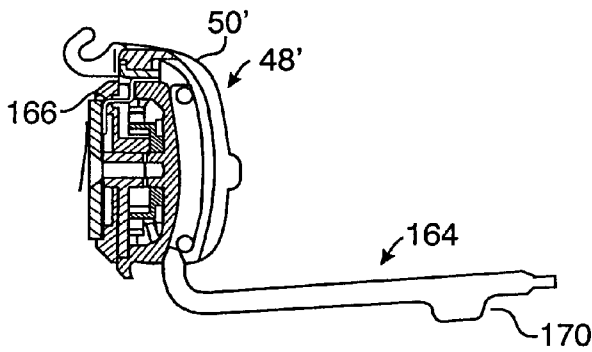

FIG. 18

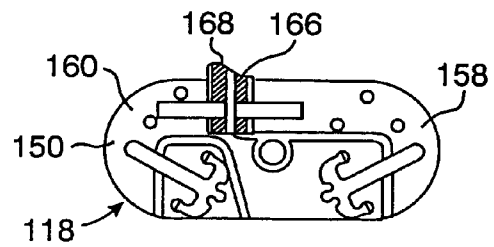

FIG. 19

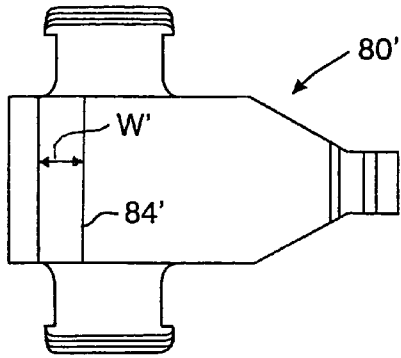

FIG. 20

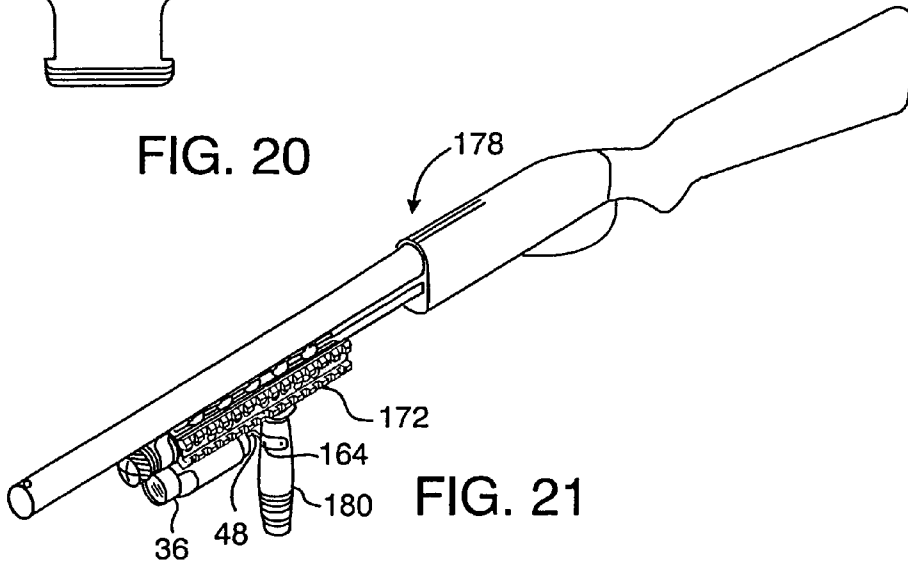

FIG. 21

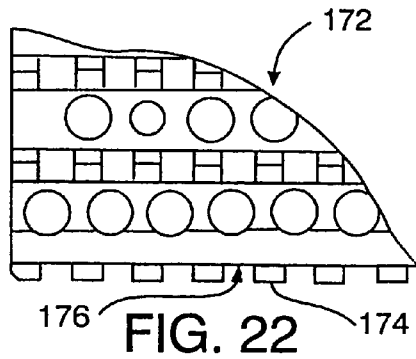

FIG. 22

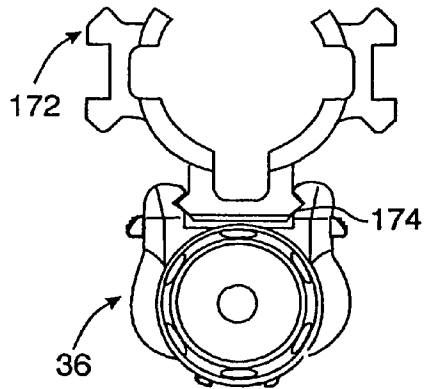

FIG. 23



**ACCESSORY DEVICES FOR FIREARMS****CROSS REFERENCE TO RELATED APPLICATION**

This application is a division of U.S. patent application Ser. No. 10/819,535, filed Apr. 6, 2004 now U.S. Pat. No. 7,117,624, incorporated in full herein by reference.

**BACKGROUND OF THE INVENTION**

This invention relates to accessory devices for being mounted to a firearm, and more particularly to a light beam generator for being mounted to a firearm including a handgun.

Accessory devices including light beam generators, such as flashlights and laser aiming devices, have long been adapted for being secured to firearms as target illuminators and laser sights. As particularly relating to handguns, such accessory devices may utilize a longitudinal rail carried by the frame of the handgun and forwardly of the trigger guard, which rail may be integral with the frame as disclosed in U.S. Pat. No. 6,276,088, or such rail may be provided as a separate structure removably attachable to the handgun as disclosed in U.S. Pat. No. 6,378,237, both patents issued to John W. Matthews and Paul Y. Kim and assigned to the assignee of the present invention, which patents are incorporated herein by reference.

Handgun manufacturers have introduced various handgun models having a longitudinal rail along the handgun's frame, below the barrel and forwardly of the trigger guard, such rail being configured with two longitudinal grooves, one along each side of the rail, and further configured with a transverse slot in the bottom surface of the rail. As is well known, such rails are intended for cooperating with accessories such as a light beam generator having a housing configured with a pair of longitudinal tongues complementing the longitudinal grooves for slidably retaining the light beam generator on the rail. A latch on the light beam generator housing co-acts with the transverse slot in the rail for releasably preventing further longitudinal movement of the light beam generator along the rail when the light beam generator is at a predetermined longitudinal position.

The longitudinal rails of handguns of some manufacturers may be of different configuration than the longitudinal rails of handguns of other manufacturers. For example, some handguns include a longitudinal rail commonly known as a Universal rail, while other handguns include a rail commonly known as a Picatinny rail. The slot width of the Universal rail is substantially less than the slot width of the Picatinny rail. Until the present invention, an accessory device securable to one type of rail was not securable to another type of rail.

**SUMMARY OF THE INVENTION**

The present invention provides an accessory device that is adapted to accommodate handguns and other firearms carrying longitudinal rails of different configurations. For example, the accessory device of the present invention may be secured to a longitudinal rail carried by a firearm having a slot width different than the slot width of another longitudinal rail carried by a firearm. In a particular example, the accessory device of the present invention accommodates a Universal rail as well as a Picatinny rail.

A preferred embodiment of the accessory device of the present invention comprises a light beam generator, such as

a target illuminator or a laser sight, that includes a removably attachable switch device for being replaced by or interchanged with another switch device having a different or modified switch configuration.

5 According to one aspect of the present invention, there is provided an accessory device for a firearm including a frame, a longitudinal barrel, a longitudinal rail carried by the frame, and a depression in the rail, the accessory device comprising: a housing; elongate members removably secured to the housing, the elongate members complementing the rail for enabling the housing to be retainably slid along the rail; and a plate pivotally secured to the housing about a transverse axis and having a free end biased away from the housing, the plate including a protuberance in the vicinity of the free end, the protuberance receivable by the depression for stopping sliding of the housing along the rail. The plate is captured to the housing by the elongate members secured to the housing, and the plate is removable from its securement about the transverse axis when the elongate members are removed from the housing.

The plate preferably includes transversely extending arms through the housing, which arms are captured to the housing by the elongate members when secured to the housing, and the arms are adapted to be urged by an operator for pivoting the plate about the transverse axis toward the housing.

In a preferred embodiment, the accessory device is a light beam generator comprising: a housing; elongate members removably secured to the housing, the elongate members complementing the rail for enabling the housing to be retainably slid along the rail; a plate pivotally secured to the housing about a transverse axis and having a free end biased away from the housing, the plate including a protuberance in the vicinity of the free end, the plate receivable by the depression for stopping sliding of the housing along the rail; a light emitter assembly carried by the housing; a battery carried by the housing in circuit for energizing the light emitter assembly when switch actuated; and a switch device including a switch actuator for the battery. The switch device preferably comprises a tail cap switch pivotally secured to the housing about a pivot axis, the tail cap switch preferably removable from its pivotal securement. The switch actuator is preferably operable by either hand of an operator when the housing is installed on the rail for placing the switch device in a CONSTANT ON or OFF position, and operable by either hand of the operator when the housing is installed on the rail for placing the switch device in a MOMENTARY ON position. A remote switch actuator may be provided for communicating with the switch device for remotely actuating the switch device to a MOMENTARY ON position.

50 According to a further aspect of the present invention, a method is provided of assembling an accessory device for installation on a first rail having a depression and carried by a firearm, comprising: providing the accessory device including a housing; providing elongate members complementing the rail; providing a plate having a protuberance in the vicinity of an end thereof, the protuberance sized for being received by the depression; pivotally securing the plate to the housing with such end biased away from the housing; and removably securing the elongate members to the housing with the elongate members capturing the plate to the housing and enabling the housing to be retainably slid along the rail. The method may further include: removing the elongate members from the housing; removing the plate from the housing; providing a second plate having a protuberance in the vicinity of an end thereof, the protuberance of the second plate sized for being received by a depression in a second rail carried by a firearm, the protuberance of the

second plate being of a different size than the protuberance in the first plate; pivotally securing the second plate to the housing with such second plate end biased away from the housing; and removably securing the elongate members to the housing with the elongate members capturing the second plate to the housing and enabling the housing to be retainably slid along the second rail.

According to yet another aspect of the present invention, there is provided a method of adapting an accessory device normally installable on a first rail carried by a firearm and having a depression, for installation on a second rail carried by a firearm and having a depression of a different size than the depression of the first rail, comprising: providing the accessory device including a housing, a first plate having a protuberance in the vicinity of an end thereof, the protuberance of the first plate sized for being received by the depression in the first rail, the plate being removably pivotally secured to the housing along a transverse axis with such end thereof biased away from the housing, and elongate members complementing the first rail and removably secured to the housing and capturing the plate to the housing, the elongate members enabling the housing to be retainably slid along the first rail; removing the elongate members from the housing; removing the first plate from the housing; providing a second plate having a protuberance in the vicinity of an end thereof sized for being received by the depression in the second rail; removably pivotally securing the second plate to the housing along a transverse axis with such end of the second plate biased away from the housing; and removably securing elongate members complementing the second rail to the housing and capturing the second plate to the housing and enabling the housing to be retainably slid along the second rail. In the elongate members securing step, the elongate members being secured may be the same elongate members removed in the elongate members removing step.

#### BRIEF DESCRIPTION OF THE DRAWINGS

The novel features believed to be characteristic of the present invention, together with further advantages thereof, will be better understood from the following description considered in connection with the accompanying drawings in which preferred embodiments of the invention are illustrated by way of example. It is to be expressly understood, however, that the drawings are for the purpose of illustration and description only and are not intended as a definition of the limits of the invention.

FIG. 1 is a side elevation view of a firearm having a longitudinal rail structure to which may be removably secured an accessory device according to the present invention;

FIG. 2 is a side elevation view of a preferred embodiment of an accessory device according to the present invention, specifically a preferred embodiment of a light beam generator, removably secured to the rail structure of the firearm of FIG. 1 (in increased scale);

FIG. 3 is a front elevation view of the firearm and secured light beam generator of FIG. 2;

FIG. 4 is an exploded side/rear perspective view of the light beam generator of FIGS. 2 and 3, illustrated during assembly of various components thereof;

FIG. 5 is a longitudinal cross-sectional view of the assembled light beam generator of FIG. 4 (in further increased scale), taken along a vertical plane along the light beam generator's longitudinal axis a' (the line 5-5 of FIG. 4) and viewed in the direction of the appended arrows;

FIG. 6 is a top plan view of a preferred embodiment of a replaceable lever latch plate (in same scale as in FIG. 5) included in the preferred embodiment of the accessory device or light beam generator;

FIG. 7 is a bottom plan view of the lever latch plate of FIG. 6;

FIG. 8 is a side elevation view of the lever latch plate of FIG. 6;

FIG. 9 is a fragmentary, part cross-sectional elevation view of an example of a rail interface member secured to the accessory device housing according to the preferred embodiment;

FIG. 10 is a cross-sectional view of the preferred embodiment of a replaceable tail cap switch assembly shown in FIG. 4, taken along a transverse plane along the longitudinal axis a' (the line 10-10 of FIG. 4) and viewed in the direction of the appended arrows;

FIG. 11 is a front elevation view of the tail cap switch assembly, which view includes the front surface of the switch circuit board with battery rear terminal contacts;

FIG. 12 is a rear view of the tail cap switch assembly circuit board of FIG. 11;

FIG. 13 is a side elevation view of the tail cap switch assembly circuit board of FIGS. 11 and 12;

FIG. 14 is a rear elevation view of the tail cap broken away to show structure of a preferred switch actuator mechanism;

FIG. 15 is a front elevation view of a tail cap insert included in the tail cap switch actuator mechanism;

FIG. 16 is a rear elevation view of an actuator arm included in the tail cap switch actuator mechanism;

FIG. 17 is a left side view of the actuator arm of FIG. 16;

FIG. 18 is a cross-sectional view of a replaceable tail cap switch assembly similar to the tail cap switch assembly shown in FIG. 5 but further including a pressure tape switch;

FIG. 19 is a rear view of the switch assembly circuit board of FIG. 18;

FIG. 20 is a top plan view of a second preferred embodiment of a replaceable lever latch plate included in the preferred embodiment of the accessory device or light beam generator;

FIG. 21 is a perspective view of a firearm to which is attached a conventional accessory rail mount structure to which is mounted the preferred embodiment of the accessory device or light beam generator of the present invention;

FIG. 22 is a side elevation view of a fragment of the front portion of the accessory rail mount exemplified in FIG. 21; and

FIG. 23 is a front elevation view of the accessory rail mount of FIG. 22 to which is mounted a light beam generator according to the present invention.

#### DETAILED DESCRIPTION OF THE PREFERRED EMBODIMENTS

Turning first to FIG. 1, there is illustrated an example of a firearm 20, specifically a handgun including a barrel 22 extending along a longitudinal axis a from the handgun's frame 24. The handgun 20 includes a trigger guard 26 in front of the handgun's trigger 28.

As used herein, "longitudinal" describes a direction along or parallel to the longitudinal axis a of the firearm's barrel, or along or parallel to the longitudinal axis a' of the light beam generator 36 (see also FIGS. 2, 4 and 5) which is parallel to the axis a when the light beam generator 36 is installed on the firearm; "transverse" describes a horizontal direction perpendicular to the axis a (or axis a') when the

5

barrel 22 (or light beam generator 36) is horizontally positioned; “above” means vertically above and “upward” means vertically upward when the firearm barrel 22 (or light beam generator 36) is horizontally positioned; “below” or “beneath” means vertically below and “downward” means vertically downward when the firearm barrel 22 (or light beam generator 36) is horizontally positioned; “front” or “forward” describes the longitudinal direction toward the muzzle of the barrel 22 or the light emitter assembly 46 (i.e., to the right as shown in FIGS. 1, 2 and 4, and to the left as shown in FIG. 5); and “rear” or “rearward” describes the longitudinal direction opposite the front or forward direction (i.e., to the left as shown in FIGS. 1, 2 and 4, and to the right as shown in FIG. 5).

The handgun 20 includes a longitudinal rail 30 along the frame 24, below the barrel 22 and forwardly of the trigger guard 26. Such rails are well known in the handgun art, for mounting accessories thereto such as a light beam generator. The rail 30 is configured with two longitudinal grooves 32, one along each side of the rail 30, and is further configured with a transverse slot 34 in the bottom surface of the rail 30. As is well known, such rails are intended for cooperating with accessories such as a light beam generator having a housing configured with a pair of longitudinal tongues (in this respect, see the tongues 38 of the preferred light beam generator 36 of the present invention as represented in FIG. 3), with such tongues 38 complementing the longitudinal grooves 32 for slidably retaining such light beam generator on the rail 30. A latch on the light beam generator housing co-acts with the transverse slot 34 in the rail 30 for releasably preventing further longitudinal movement of the light beam generator along the rail 30 when the light beam generator is at a predetermined position along the rail 30.

Although the rail 30 is represented in FIG. 1 as being integral with the frame 24 of the handgun 20, the rail 30 may also be provided as a separate structure that may be removably attached to the handgun beneath the barrel and forwardly of the trigger guard. As previously noted, such rails for handguns, both integral to the frame and removably attachable to the handgun, as well as light beam generators adapted for being removably attached to such rails as discussed above, are disclosed in the aforementioned U.S. Pat. Nos. 6,276,088 and 6,378,237 incorporated herein by reference.

Handgun manufacturers have introduced various handgun models with integral rails having longitudinal grooves of the type shown in FIGS. 1-3. Although such longitudinal grooves among manufacturers have been of substantially similar dimensions, the transverse slots in the rails of handguns of some manufacturers are of different width than the transverse slot in the rails of handguns of other manufacturers. Specifically, the rails of some handguns include a transverse slot of one predetermined width while the rails of other handguns include a transverse slot of another predetermined width. For example, some handguns include a rail commonly known as a Universal rail, while other handguns include a rail commonly known as a Picatinny rail; the slot width of the Universal rail is substantially less than the slot width of the Picatinny rail. The accessory device or light beam generator 36 of the present invention accommodates both types of rails.

The light beam generator 36 further includes a removably attachable switch device, for being replaced by or interchanged with another switch device having a different or modified switch configuration.

Turning also to FIGS. 4-8, the light beam generator 36 includes a housing 40 in which is contained a power source

6

such as a battery 42 of one or more battery cells 44 (for example, two 3-volt lithium battery cells 44). A light emitter assembly 46 is carried by the housing 40 forwardly of the battery 42 and in circuit with a positive front terminal of one of the battery cells 44 and a negative front terminal of another of the battery cells 44. A switch device 48 preferably situated at the rear of the housing 40 in and including a tail cap 50, includes a switch actuator assembly 49 for selectively completing and opening the light emitter energization circuit. In the embodiment shown, this is accomplished by the switch actuator assembly 49 establishing a conductive path between the rear positive terminal 43 of one of the battery cells 44 and the rear negative terminal 45 of the other of the battery cells 44 for placing the switch device 48 in an ON position for causing the battery 42 to energize the light emitter assembly 46, and by opening such conductive path for placing the switch in an OFF position where the battery 42 does not energize the light emitter assembly 46.

As shown in FIG. 5, a preferred light emitter assembly 46 may include a light emitter 52 such as a light emitting diode (LED), preferably a high luminous flux LED such as a 3-watt or 5-watt LED manufactured by Lumileds Lighting, LLC (of San Jose, Calif.) and marketed under the trademark LUXEON including such LEDs marketed under the LUXEON STAR trademark.

With such an LED as the light emitter 52, the emitted light may be directed by a lens system contained in the light emitter assembly 46 including a totally internal reflective (TIR) lens 54 (as represented in FIG. 5), or by a parabolic reflector system as disclosed in U.S. patent application Ser. No. 10/346,537 of Paul Y. Kim and William A. Hunt, assigned to the assignee of the present invention, which patent application is incorporated herein by reference. The light emitter assembly 46 may alternatively include an incandescent lamp as the light emitter 52, such as a high intensity tungsten light bulb, with the emitted light preferably directed by a parabolic reflector.

In either case, the light emitter assembly 46 may further include a controller 56 for regulating the power to the light emitter for providing light output of constant brightness with decreasing battery voltage over time. The use of such controllers is discussed in the aforesaid patent application Ser. No. 10/346,537 incorporated herein by reference.

The preferred embodiment of the housing 40 of the light beam generator 36 of the present invention includes a substantially flat upwardly facing surface 58 with two upstanding first wall segments 60 longitudinally extending forwardly along opposite sides of the surface 58 from the vicinity of the housing's rear end 62, and two upstanding second wall segments 64 forwardly of the respective first wall segments 60. The forward generally vertical ends 66 of the respective first wall segments are transversely aligned, and the rear generally vertical ends 68 of the respective second wall segments 64 are transversely aligned and spaced from the second wall segments' forward ends 68 by a predetermined distance d.

A transversely disposed pin 70 is secured to the housing 40 in the vicinity of its rear end 62 and above the housing's flat surface 58. As shown in FIG. 4, the transverse pin 70 is secured to the first wall segments 60 in the vicinity of their rear ends and above the flat surface 58. The pin 70 additionally extends through apertures in two upstanding protruberances or partitions 72 from the flat surface 58. The two partitions 72 are laterally spaced so as to divide the transverse pin into three exposed segments 74, 76, 78 which may be of substantially equal lengths.

The light beam generator **36** includes a latch lever plate **80** having a generally U-shaped rear end **82** configured for receiving the middle segment **76** of the transverse pin **70**. One leg (preferably the upper leg **83**) of the U may curve over a portion of the generally rearwardly facing opening of the U, and the plate **80** is preferably made of a material such that the legs are somewhat resilient. As illustrated in FIG. 4, the latch plate **80** is installed to the housing **36** by placing the opening of the latch plate's rear end **82** to the transverse pin segment **76**, and the installer urging the rear end **82** to snap onto the pin segment **76**. The latch plate **80** accordingly is hinged at its rear end **82** about the transverse hinge pin **70**, specifically about the hinge pin segment **76**; i.e., the plate **80** is pivotally secured to the housing **40** about a transverse axis along the pin **70**.

The top surface of the plate **80** includes an upstanding protuberance, preferably a transversely disposed elongate protuberance **84**, in the vicinity of the plate's front end **86**, the elongate projection **84** having a width  $w$  (along the longitudinal direction) slightly less than the slot **34** of the firearm's rail **30** for being received therein. Lateral arms **88** transversely extend outwardly from opposite sides of the plate **80**, the arms **88** situated in the vicinity of the plate's front end **86** and being of a width  $d'$  (along the longitudinal direction) slightly less the distance  $d$  between the forward ends **66** of the first wall segments **60** and the respective rear ends **68** of the second wall segments **64** (see FIG. 4) such that the arms **88** are received between such ends **66** and **68**. The vertical height of the end portions **66** and **68** is preferably greater than the sum of the vertical thickness of the plate **80** and the vertical height of the protuberance **84**.

During installation of the plate **80** to the housing **40**, after being hinged to the hinge pin segment **76** the plate **80** is pivoted toward the housing's upwardly facing surface **58** (i.e., in the clockwise direction as viewed in FIG. 4) with a wave spring **90** held by an annular groove **92** in the underside of the plate **80** (see also FIGS. 5 and 7) in the longitudinal vicinity of the protuberance **84** and the lateral arms **88**, until the spring **90** contacts the flat upwardly facing surface **58** of the housing **40** while the lateral arms **88** of the plate **80** are caused to enter the space between the wall surfaces **66** and **68**.

The accessory device or light beam generator **36** includes two elongate members **94** removably secured to the housing **40**, for interfacing with the firearm rail **30** to enable the housing **40** to be retainably slid along the rail **30** (see, in particular, FIGS. 1, 2, 3 and 5). Each elongate member **94** includes an inwardly directed tongue **38** longitudinally extending along such member **94**; i.e., such elongate rail interface members **94** are installed to the housing **40** with the longitudinal tongue **38** of one of the members **94** facing the longitudinal tongue **38** of the other of the members **94**, the tongues **38** complementing the firearm's longitudinal grooves **32** for slidably cooperating with the firearm's longitudinal grooves **32** while being vertically retained by the rail **30** as shown in FIGS. 2 and 3.

The elongate rail interface members **94** are installed to the housing **40** after the latch plate **80** has been hinged to the hinge pin segment **76** and pivoted with its lateral arms **88** in the space between the upstanding wall segment ends **66** and **68** as discussed above. Each member **94** includes a flat bottom surface **96** for contacting the top surfaces **98** and **100** of the housing's respective wall segments **60** and **64**. The members **94** include bores **102** therethrough aligned with internally threaded blind vertical bores **104** in the top surfaces **98**, **100** of the housing's wall segments **60**, **64**, preferably forwardly of the wall segment ends **68** and

rearwardly of the wall segment ends **66**, the members **94** being removably secured to the wall segments **60**, **64** by headed screws **106** respectively extending into the bores **102** through the member **94** and threaded into the respectively aligned threaded bores **104** in the housing **40**. With the elongate members **94** so installed, their bottom surfaces **96**—which contact and extend along the top surfaces **98**, **100** of the wall segments **60**, **64**—bridge the wall segments **60**, **64** and provide a ceiling to the space between the wall ends **66**, **68**. Such bridge or ceiling upwardly captures the lateral arms **88** within such space, while the wall ends **66**, **68** longitudinally captures the lateral arms **88** within such space, resulting in the hinged latch plate **80** being captured to the housing **40** as well.

The elongate rail interface members **94** may be removed from the housing **40** by unscrewing the screws **106**, and if desired the elongate rail interface members **94** may be replaced by other or different elongate rail interface members which are similarly removably securable to the housing **40**. It may be appreciated that when the rail interface members **94** have been removed from the housing **40**, the lateral arms **88** of the hinged latch plate **80** are no longer upwardly blocked or captured by the members **94**, so that the latch plate **80** may be pivoted about the hinge pin **70** away from the surface **58** of the housing **40** and pulled away from the hinge pin segment **76**. In such manner, the latch plate **80** may be removed from the housing **40** and another or different latch plate **80**, which is similarly removably securable to the housing **40**, may be hinged to the hinge pin **70** and upwardly captured by reinstalling the rail interface members **94**.

Another feature of the preferred embodiment of the light beam generator **36** of the present invention comprises the tail cap switch device **48** which functions both as a battery cover permitting the battery cells **44** to be installed and retained in the housing **40** and as a switch for actuating the battery **42** to selectively energize the light emitter of the light emitter assembly **46**. The preferred embodiment of the tail cap switch **48** is removably securable to the rear end **62** of the housing **40**.

The switch device **48** includes a tail cap **50** which is hinged to the transverse hinge pin **70** by two transversely spaced-apart forward projections **108** each having a generally U-shaped end portion, one leg of the U preferably curving over a portion of the generally upwardly and rearwardly facing opening of the U. The projections **108** are preferably somewhat resilient and, as illustrated in FIG. 4, the switch device **48** is installed to the housing **36** by placing the openings of the cap's projections **108** to the transverse pin outer segments **74** and **78**, the installer urging the projections **108** to snap onto the pin segments **74**, **78**. The tail cap **50** accordingly is hinged about the transverse hinge pin **70**, specifically about the hinge pin segments **74**, **78**; i.e., the tail cap switch is pivotally secured to the housing **40** about a pivot axis, preferably the transverse axis  $t$ .

The installer thereupon rotates the tail cap **50** toward the housing's open rear end **62** (i.e., counterclockwise as viewed in FIG. 4) until the rear opening of the housing **40** is closed and the tail cap **50** is locked into place by cooperation of a catch **110** along the lower edge of the tail cap **50** with a spring-biased latch **112** on the housing **40** (FIGS. 4 and 5). When the tail cap **50** is in its latched position, the forwardly facing battery contacts **114**, **116** on the switch device circuit board **118** are in conductive contact with the respective rear battery terminals **43**, **45**.

The switch device **48** may be removed from the housing **40** by manually unlatching the latch **112**, pivoting the tail

cap **50** upwardly about the hinge pin **70** away from the housing's rear opening (for example, to the position generally illustrated in FIG. **4**) and pulling the switch device **48** away from the hinge pin segments **74** and **78**. In such manner, the switch device **48** may be removed from the housing **40** and another or different switch device, which is similarly removably securable to the housing **40**, may be hinged to the hinge pin **70** and locked to the rear end **62** of the housing **40** by operation of the latch **112**.

When the light beam generator **36** is in its assembled condition (i.e., with the tail cap switch **48**, latch plate **80** and rail interface members **94** installed to the housing **40** as described above), the assembled light beam generator **36** may be removably installed to the firearm **20**. The light beam generator **36** is placed to the firearm **20** with the rear ends of the tongues **38** of the rail interface members **94** respectively engaging the forward ends of the grooves **32** of the rail **30** carried by the firearm **20**. The light beam generator **36** is thereupon rearwardly urged, thereby sliding the housing **40** along the rail **30** while the housing **40** is being vertically retained by the rail **30**. When the transverse upstanding protuberance **84** of the latch plate **80** contacts the bottom surface of the rail **30** (which may be facilitated by a swept-back profile of the forward portion of the rail **30** illustrated in FIGS. **1** and **2**, preferably of a height at least as great as the height of the protuberance **84**), the latch plate is thereby urged to pivot about the hinge pin **70** against the bias of the spring **90**, until the transverse protuberance **84** enters the transverse slot **34** as the spring **90** urges the plate **80** to pivot about the hinge pin segment **76**.

As earlier noted, the width *w* of the protuberance **84** is slightly less than the width of the slot **34** such that the protuberance **84** just fits into the slot **34**. The engagement of the protuberance **84** with the slot **34** stops further longitudinal movement of the housing **40** along the rail **30**, longitudinally latching the housing **40** in this position. The longitudinal positions of the slot **34** and of the protuberance **84** are preferably predetermined such that the rear end of the tail cap **50** is situated just forwardly of the handgun's trigger guard **26** when the protuberance **84** engages the slot **34**.

Because the dimensional tolerances of rails **30** may differ among firearm manufacturers, and even among firearms manufactured by the same manufacturer, the rail interface members **94** may be configured to accommodate such differences. In a preferred embodiment of the rail interface members **94** for accommodating such differences, the bores **102** and the counterbores **103** in the rail interface members **94** may be slightly greater in at least the transverse direction than the respective diameters of the threaded shaft **107** and head **109** of the screws **106**, for providing a loose fit in at least the transverse direction between the screws **106** and the bore **102**/counterbore **103** combinations. For example, the diameters of the screw-head **109** and threaded shaft **107** may be slightly greater than the diameters of the counterbore **103** and bore **102**, respectively.

During installation of the light beam generator **36** to a particular firearm rail **30**, if the engagement of rail interface members **94** to the rail **30** is too loose, the installer may simply loosen the screws **106**, move the rail interface members **94** inwardly (transversely toward each other) and thereupon tighten the screws **106** with the screw-heads **109** urged against the peripheral floor annular ledge **105** of the counterbores **103**. If the engagement between the rail interface members **94** and the rail **30** is too tight, the installer may loosen the screws **106**, move the rail interface members **94** outwardly (transversely away from each other), and tighten

the screws **106** with the bottom surface **111** of the screw-heads **109** urged against the peripheral floor or annular ledge **105** of the counterbores **103**.

To remove the accessory device **36** from the firearm **20**, the operator downwardly urges the laterally protruding handles **120** on the ends of the lateral arms **88**, causing the plate **80** to pivot about the hinge pin **70**, against the bias of the spring **90**, until the protuberance **84** is disengaged from the transverse slot **34**. The operator thereupon forwardly urges the accessory device **36** to slide along the rail **30** until the accessory device **36** is removed therefrom.

A preferred embodiment of the tail cap switch device **48** of the present invention permits ambidextrous actuation of the switch device **48** for energizing the light emitter **52** in a CONSTANT ON/OFF mode as well as in a MOMENTARY ON mode. The switch mechanism for implementing such operation is shown in FIGS. **10-17**.

A switch actuator arm **122** (e.g. fabricated of stainless steel) is affixed to an actuator disk **124** (e.g. fabricated of a polymeric material) rotatable about a circular protuberance **125** along the longitudinal axis *a'*. The actuator disk **124** is also rotatable about an elastomeric washer **127** (e.g. fabricated of rubber) rearwardly projecting from the tail cap insert **130** and having a rearwardly facing annular rim **128** adjacent to the forward surface of the actuator disk **124**.

The actuator disk **124** is rotatable with the actuator arm **122** about the longitudinal axis *a'*. The disk **124** includes peripheral notches **126** engaged by ends of a latching spring **129** secured to the tail cap insert **130**, for latching the disk **124** and hence the actuator arm **122** in a first rotational position where the arm **122** is transversely oriented (FIG. **14**), a second rotational position where the arm **122** is rotated clockwise by a predetermined angle (say, approximately 20°), and a third rotational position where the arm **122** is rotated counterclockwise by a predetermined angle (say, approximately 20°). An operator may selectively rotate the arm into these three alternative latched positions by manipulating up or down either one of the handles **132** attached to the ends of the actuator arm **122**.

The tail cap insert **130** includes a plate **134** (preferably of a plastic material such as polypropylene), having two rearwardly projecting nubs **136** at the free ends of flexible fingers **138** formed by cuts **140** through the insert plate **134**. The end portions **142** of the actuator arm **122** are situated just to the rear of the rearwardly projecting nubs **136**. Angularly extending from each of the actuator arm end portions **142** is a forwardly stepped tab **144**. The end portions **142** of the actuator arm **122** are normally situated longitudinally just to the rear of the rearwardly projecting nubs **136** when the actuator arm **122** is in its latched first or transverse position. However, when the actuator arm **122** is in either of its latched second or third rotated positions, one of the forwardly stepped tabs **144** contacts one of the nubs **136** and urges such contacted nub **136** to be forwardly displaced. When the operator rotatably replaces the actuator arm **122** to its latched first or transverse position, the corresponding resilient finger **138** replaces the affected nub **136** to its normal or unactuated position.

When the switch actuator arm **122** is in its latched first rotational or transverse position, the operator may push either of the handles **132** in the forward direction, causing the actuator arm **122** to compress a peripheral portion of the elastomeric rimmed washer **127**, rocking the actuator arm **122** so that its pushed end portion **142** is caused to be forwardly displaced. Such end portion **142** contacts and forwardly urges the correspondingly situated nub **136** for such time that the handle **132** is forwardly urged by the

operator. When the operator releases the handle **132**, the resiliency of the washer **127** replaces the actuator arm **122** end portion **142** to its normal undepressed position thereby permitting the resilient finger **138** of the affected nub **136** to replace such nub **136** in its normal unactuated position.

It may be appreciated that the forward displacement of the actuator arm ends, and their resilient replacement, may be implemented by other mechanisms, for example by increasing the longitudinal elasticity of the actuator arm itself.

The forward face of the insert plate **134** is covered with a non-conductive elastomeric sheet, such as a rubber membrane **146** secured to the plate **134**. The tail cap insert **130** is mounted within the tail cap **50** by screw **148**, with the rubber membrane **146** obverse and in proximity to the rear face **150** of the tail cap battery terminal circuit board **118** also secured to the tail cap **50** by the screw **148**. The respective free end portions **151**, **153** of the resilient contacts **152**, **154** secured to the tail cap circuit board's rear face **150** are situated directly forwardly of the nubs **136** with the rubber membrane **146** interposed therebetween. When a nub **136** is forwardly displaced, such nub **136** presses (through the interposed rubber membrane **146**) the corresponding resilient contact's end portion **151** or **153** into contact engagement with the circuit board's rear face **150**.

When the tail cap **50** is installed and latched to the housing **40**, the battery contacts **114**, **116** secured to the circuit board's forward face **156** are in contact engagement with the respective battery cell terminals **43**, **45**; i.e., the battery contact **114** is in contact engagement with the positive terminal **43** of one of the battery cells **44**, and the battery contact **116** is in contact engagement with the negative terminal **45** of the other of the battery cells **44**.

The positive battery contact **114** conductively communicates with a first conductive area **158** (FIG. **11**) on the rear surface **150** of the circuit board **118**, while the negative battery contact **116** conductively communicates with a second conductive area **160** on the rear face **150** of the circuit board **118** to which the resilient contact **154** is conductively secured. When the free end **153** of resilient contact **154** on the circuit board's rear face **150** is urged into contact engagement with the first conductive area **158**, there is established a conductive path between the negative battery terminal contact **116** and the positive battery terminal contact **114** (and hence between the negative and positive battery terminals **45**, **43**), thereby placing the switch device **48** in an ON position completing the electrical circuit between the battery **42** and the light emitter assembly **46**.

The positive battery terminal **114** is conductively secured to a third conductive area **162** (FIG. **11**) on the forward face **156** of the circuit board **118**, while the resilient contact **152** on the circuit board's rear face **150** (but which is normally electrically isolated from the conductive areas on the circuit board's rear face **150**) conductively communicates with the conductive area **162** on the circuit board's forward face **156**. When the free end **151** of the resilient contact **152** is urged into contact engagement with the second conductive area **160** on the circuit board's rear face **150**, there is established a conductive path between the positive battery terminal contact **114** and the negative battery terminal contact **116** (and hence between the positive and negative battery terminals **43**, **45**), thereby placing the switch device **48** in an ON position completing the electrical circuit between the battery **42** and the light emitter assembly **46**.

The switch device **48** is in an OFF position when the actuator arm **122** is in its normal position, i.e. in its first latched or transverse position and with neither of its end portions **142** forwardly depressed. It may be appreciated that

when an operator manually urges either one of the handles **132** either downwardly or upwardly, the actuator arm **122** is rotated into either one of its latched second or third positions thereby placing the switch **48** in a CONSTANT ON position. The switch **48** remains in such CONSTANT ON position until the operator manually urges either one of the actuator arm handles **132** to effect a reverse rotation of the actuator arm **122** for causing the actuator arm **122** to be replaced in its latched first or transverse position, in which position the switch **48** is placed and maintained in its normal OFF position until further actuation by the operator.

It may be appreciated, as well, that the switch **48** may be actuated from an OFF position to a MOMENTARY ON position. When the actuator arm **122** is in its latched first or transverse position, the operator may manually forwardly urge or depress either one of the actuator arm handles **132**, placing the switch **48** in its ON position for only as long as the operator continues to depress the handle **132**. When the operator releases the handle **132**, the switch **48** resumes its normal OFF position.

An important feature of the preferred embodiment of the switch **48** is its ability to be actuated by either hand of the operator, in placing the switch **48** in its CONSTANT ON position and back to its normal OFF position, as well as for placing the switch **48** in its MOMENTARY ON position.

A second preferred tail cap switch embodiment **48'** is shown in FIGS. **18** and **19**. This second embodiment **48'** is substantially the same as the first switch embodiment **48** except that, in addition to the CONSTANT ON/OFF and MOMENTARY ON switch operations actuatable upon manipulation of either of the handles **132** at the ends of the switch actuator arm **122**, the second switch embodiment **48'** further includes a MOMENTARY ON remote switching capability provided by a type of switch commonly known as a slimline or tape switch **164**. Tape switches are well known in the art, and their construction typically includes spaced electrodes in a flexible enclosure to which pressure may be manually applied by an operator for squeezing the electrodes together thereby bringing them into electrical contact with each other. The electrodes resume their spaced condition when the operator discontinues the application of such pressure. Tape switches used with illumination apparatus removably attachable to handguns are described in U.S. Pat. No. 5,654,594 issued to Bernie E. Bjornsen, III, Peter Hauk and John W. Matthews and assigned to the assignee of the present invention, and in U.S. Pat. No. 6,276,088 issued to John W. Matthews and Paul Y. Kim and assigned to the assignee of the present invention, which patents are incorporated herein by reference.

The tape switch **164** which may be utilized in connection with the second preferred embodiment **48'** of the tail cap switch device includes two electrically conductive leads **166**, **168** insulated from each other and extending from the tail cap **50'** to a pressure sensitive switch actuator **170** remote from the tail cap **50'**. The switch actuator **170** may be positioned under the trigger guard **26** (as shown in phantom in FIG. **2**), or the switch actuator **170** may be of a type which horseshoes about the handgun grip as shown in the aforementioned U.S. Pat. Nos. 5,654,594 and 6,276,088.

The tail cap-situated ends of the conductive leads **166**, **168** are conductively secured to the tail cap circuit board **118** for conductively communicating with the positive and negative battery cell contacts **114**, **116**. As shown in FIG. **19**, the tape switch lead **166** is conductively secured to the first conductive area **158** of the circuit board's rear face **150**, which conductive area **158** conductively communicates with the positive battery contact **114** on the circuit board's

forward face **156** as previously described. The tape switch lead **168** is conductively secured to the conductive area **160** on the circuit board's rear face **150**, which conductive area **160** conductively communicates with the battery cell negative terminal contact **116** on the circuit board's forward face **156** as previously described. Accordingly, when the circuit of the tape switch **164** is closed upon the application of pressure to the tape switch actuator **170**, the battery cell positive terminal **43** is conductively connected to the battery cell negative terminal **45** during such time that actuating pressure is continued to be applied to the tape switch actuator **170**.

It should be noted that, like the two switching modes of the tail cap switch **48** permitted by the switch actuator arm **122**, the remotely situated tape switch actuator **170** (whether situated under the trigger guard or horseshoed about the front of the handgun grip) may be operated with either of the operator's hands and, in addition, the tape switch actuator **170** may be operated by the same hand used for pulling the handgun's trigger.

It has been noted that the latch plate **80**, described in connection with FIG. 6, includes a transversely disposed elongate protuberance **84** having a width  $w$  slightly less than the slot **34** of the firearm's rail **30** for being received therein. Different firearm rails may have different slot widths, and indeed two well-known types of rails (namely, a Universal rail and a Picatinny rail) have slots of respectively different standardized widths. In order to accommodate both types of rails, the preferred embodiment of the accessory device **36** of the present invention may be provided with two types of replaceable latch plates. For example, the accessory device **36** may be provided with a latch plate **80** having a protuberance width  $w$  of approximately 0.125 inch for accommodating the transverse slot in a Universal rail, while another latch plate **80'** (shown in FIG. 20) may be provided having a width  $w'$  of its transversely disposed elongate protuberance **84'** of approximately 0.205 inch for accommodating the transverse slot of a Picatinny rail. Except for the differences in the width of the transverse protuberance shown as examples of the latch plate **80** and the latch plate **80'**, the two latch plates **80**, **80'** are substantially identical and one may be substituted for the other in the accessory device **36** according to the present invention.

Accessory devices according to the present invention, including the preferred embodiment **36** thereof, may be removably secured to firearms other than handguns, as well as to other types of firearms that do not have integral rails but are adapted for having accessory rail mount system devices secured thereto. Such rail mount system devices are well known in the firearms art, and may be of the type **172** (see FIG. 21) comprising a series of longitudinally spaced-apart ribs **174** separated by transverse slots **176**, such as a Picatinny rail specified in MIL-STD-1913 incorporated herein by reference.

Such rail mount structures **172** may be secured to long arms, for example to a rifle or shotgun **176** illustrated in FIG. 21 and as further disclosed in U.S. Pat. No. 6,655,069 issued to Paul Y. Kim and incorporated herein by reference. Other examples of rail structures **172**, including Picatinny rails, on other types of firearms are disclosed in U.S. Pat. Nos. 6,508,027 and 6,622,416, both issued to Paul Y. Kim and incorporated herein by reference; and in U.S. patent application Ser. No. 10/447,874 of Paul Y. Kim and John W. Matthews, assigned to the assignee of the present invention and incorporated herein by reference.

As shown in FIGS. 21 and 23, the accessory device or light beam generator **36** may be removably secured to such

rail structures **172** secured to firearms other than hand weapons. Where such rail structure **172** is of a type having Picatinny rails, the latch plate **80'** shown in FIG. 20 would be installed in the accessory device **36**, with the transverse protrusion **34'** having a width  $w'$  for matingly engaging any one of the Picatinny rail slots **176**. The accessory device **36** may be removably secured to the rail structure **172** in substantially the same way as the accessory device **36** may be removably secured to the rail **30** carried by the handgun **20**. The operator may adjust the longitudinal position of the accessory **36** on the rail by depressing the handles **120** until a selected slot **176** has been encountered by the protuberance **34**.

As shown in FIG. 21, a handgrip **180** may be secured to the rail structure **172**, rearwardly of the light beam generator **36** but in proximity with the tail cap for permitting the operator to conveniently operate the tail cap switch device. In addition, FIG. 21 shows a tape switch **164** connected to the tail cap and having an actuator horseshoed about the front of the handgrip **180**. In such configuration, and if both the accessory device **36** and the handgrip **180** are secured to the bottom rail **172** (as illustrated in FIG. 23), the tail cap switch **48** may be actuated in both the CONSTANT ON/OFF and MOMENTARY ON modes with either hand.

The accessory device or light beam generator **36** of the present invention, and in particular the housing **40**, elongate members **94**, pivot plate **80** and tail cap **50** may be manufactured using fabrication methods well-known in the art, of well known materials typically used in the art of making such components including rigid and durable materials such as polymeric materials as well as light weight aluminum alloys.

Although a target illuminator embodiment of the light beam generator **36** is described above in detail, laser aiming devices securable to rails carried by firearms are included within the scope of light beam generators according to the present invention.

Thus, there has been described a preferred embodiment of an accessory device which is removably securable to a longitudinal rail carried by a firearm, and which accommodates longitudinal rails of different configurations carried by firearms. The light beam generator of the preferred embodiment includes a removable tail cap switch actuable by either hand of an operator for placing the switch in CONSTANT ON/OFF positions and in a MOMENTARY ON position, as well as for remote actuation by either hand to a MOMENTARY ON position. Other embodiments of the present invention, and variations of the embodiments presented herein, may be developed without departing from the essential characteristics thereof. Accordingly, the invention should be limited only by the scope of the claims listed below.

I claim:

1. An accessory device for a firearm including a barrel having a longitudinal axis, the accessory device comprising: a housing having a longitudinal axis, said housing adapted to be removably secured to said firearm with said longitudinal axis of said housing parallel to the longitudinal axis of the barrel;
- a light emitter assembly carried by said housing;
- a battery carried by said housing in circuit for energizing said light emitter assembly when switch actuated; and
- a switch device secured to said housing, including a switch actuator having an actuator arm rotatably urgeable by either hand of an operator clockwise or counterclockwise about the longitudinal direction of said housing for placing said switch device in a CON-

15

STANT ON position from an OFF position, said actuator arm reverse rotatably urgeable by the operator for returning said switch device to the OFF position, and said actuator arm having ends each longitudinally urgeable by the operator from the OFF position for placing said switch device in a MOMENTARY ON position. 5

2. The accessory device according to claim 1, including: a remote switch actuator communicating with said switch device operable for placing said switch device in a MOMENTARY ON position. 10

3. The accessory device according to claim 1, wherein: said actuator arm includes handles at said ends, one of said handles accessible to one hand of the operator and the other of said handles accessible to the other hand of the operator; 15

said switch actuator is adapted for placing said switch in the CONSTANT ON position when either of said handles is upwardly or downwardly urged by the operator from the OFF position, and for returning said switch device to the OFF position upon reverse urging of either of said handles; and 20

said switch actuator is adapted for placing said switch in the MOMENTARY ON position when either of said handles is forwardly urged from the OFF position by the operator. 25

4. The accessory device according to claim 1, wherein: said switch actuator is latched in the OFF position when said actuator arm is transversely oriented, and said

16

switch actuator is latched in the CONSTANT ON position when said actuator arm is rotatably displaced from its transverse orientation.

5. The accessory device according to claim 3, wherein: said switch device comprises a tail cap switch device pivotally secured to said housing about a pivot axis.

6. The accessory device according to claim 5, wherein: said tail cap switch device is adapted for being removed by an operator from its securement about said pivot axis.

7. The accessory device according to claim 1, wherein: said switch device comprises a tail cap switch device pivotally secured to said housing about a pivot axis.

8. The accessory device according to claim 7, wherein: said tail cap switch device is adapted to be removed by an operator from its securement about said pivot axis.

9. The accessory device according to claim 7, wherein: said tail cap switch device is adapted to be removed by an operator from its securement about said pivot axis when said tail cap switch device is pivoted away from said housing.

10. The accessory device according to claim 1, wherein: said switch device comprises a tail cap switch device.

11. The accessory device according to claim 3, wherein: said switch device comprises a tail cap switch device.

\* \* \* \* \*